

# Mimeo Cassette Interface Assembly and Operations Guide

By Mike Willegal

[www.willegal.net](http://www.willegal.net)

version 0.12

## CAUTION!!!

Incorrect assembly or connecting of the Mimeo Cassette Interface can cause fatal damage to the interface and/or the motherboard. Double and triple check your connections before powering on. Pay special attention to orientation of the card when you plug it into the motherboard's expansion slot. Plugging it in backwards will result in damage to the card and/or motherboard.

## Forward

In the mid 1970's, around the time the Apple 1 was developed, the only reasonably affordable interface for home computer hobbyist was repurposing an ordinary cassette recorder as a data storage device. Soon after the introduction of the Apple 1, Apple Computer released the Apple Cassette Interface (ACI) for the Apple 1. This small card had a list price of \$75 and turned out to be the only peripheral card that Apple ever released for the Apple 1. The Mimeo Cassette Interface is a clone of Apple's original ACI, duplicating the form, fit and function of the original ACI in exacting detail. This manual refers to the board as the ACI, since that is the name Apple used and for all intents and purposes the implementations and operation are identical.

## Reliability

Reliability of the ACI card, in it's stock form, is not very good by 21st century standards. Apple made improvements to the cassette interface circuit when it came out with the Apple II. I have spent considerable effort looking for improvements in reliability, without altering the design of the original ACI printed circuit board. In the end, I have found three items that can help with reliability,

Two of these involve changing component values. I am providing parts that can be used to build the board with either original component values or with components that will improve reliability. Because of the reliability problems with the original design, I recommend building this kit with the components that improve reliability. Look and feel of the board is not affected but reliability is improved quite a bit. Even with these changes, reliability is not perfect, but the system will be more reliable.

The third reliability improvement I recommend, is using an Apple recommended cassette recorder. I have had great difficulty with a different vintage cassette recorder that works quite well with an Apple II. The good news is that the original Apple recommended recorder happens to remain on the market. There is a Panasonic RQ-2102. There may be other cassette recorders that perform as well or better than the RQ2102, but I don't have the time or resources to investigate the possibilities.

## **Chapter 1 – Assemble Components, Tools, and Equipment**

### **1. Recommended Tools and Equipment**

- Quality soldering station - I use a Weller WES51. Whatever you use, I recommend that it has some kind of temperature controlled tip. This will help prevent damage to the PCB when soldering. Soldering irons that do not have a temperature controlled tip can overheat and damage the PCB or component being soldered
- Solder - use quality solder - thinner solder is vastly easier to work with than fat solder. The fat stuff sold at hardware stores is not suitable for these sort of electronics projects
- Wire cutters – for trimming component leads and cutting wire to length
- Wire strippers - for stripping ends of jumper wire
- Your favorite PCB cleaning agent - Isopropyl Alcohol will dissolve many kinds of soldering resin. Windex will also help with cleaning PCBs
- Ohm meter - to check for good connections and shorts
- Logic probe or oscilloscope – handy if you are having trouble with bring up
- Your host computer schematics or hardware interfacing guide – Direction for connecting to Mimeo 1 computers are provided in this manual

### **2. Additional Components (not included)**

- Cassette Recorder - I strongly recommend the Panasonic RQ-2102
- Cassette Tapes - ordinary 30 or 60 minute tapes work well
- Two mono to mono 1/8" audio cables. One end plugs into the ACI, the other into jacks on the cassette recorder

### 3. Compare Received Components With Parts List

Examine and identify all parts provided with the kit.

PART	DESCRIPTION	QUANTITY	PRESENT
16 pin socket	For PROMs	2	
14 pin socket	For 74LS parts	3	
8 pin socket	For LM311	1	
LM311	Voltage comparator	1	
74LS02	Quad 2 input nor gate	1	
74LS10	Triple 3 input nand gate	1	
74LS74	Dual D type flip flop	1	
7474	Reliability improvement replacement for 74LS74	1	
6301 - APPLE-A3	256x4 PROM - location A3	1	
6301 - APPLE-A4	256x4 PROM - location A4	1	
.01uF capacitor	Input coupling capacitor	1	
.1uF capacitor	Reliability improvement replacement for .01uF	1	
100 ohm	brown-black-brown Low part of voltage divider for tape output & current limiter for LED input monitor	2	
3K resistor	orange-black-red Voltage comparator feedback	1	
10K resistor	brown-black-orange-gold High part of voltage divider for tape output	1	
10K 1% resistor	brown-black-orange-black-brown Voltage dividers for inputs to voltage comparator	4	
47K resistor	yellow-violet-orange Voltage comparator feedback	1	
100K resistor	brown-black-yellow Sense resistor for input monitor LED	1	
PCB	Printed circuit board	1	
MPS3704	Sense transistors for input monitor LED	2	
RED LED	Read level indicator	1	
Audio Jacks	Switchcraft #41	2	
1' jumper wire	For jumpering from audio jack to PCB	1	
<b>PARTS COUNT</b>		<b>32</b>	
<b>COUNT OF TYPES</b>		<b>23</b>	

## Chapter 2 – Solder In Components

### 1. Overview

The key thing here is to check orientation and make sure that you don't put the sockets or transistors in wrong. For the IC sockets, make sure that the parts are oriented correctly with pin 1 of the socket or chip near the edge of the PCB that contains the gold fingers. All components go on the front of the board (the side with the words "Apple Cassette Interface 1" etched in copper).

Make sure the socket or chip is fully seated. I accomplish this by resting the socket upside down on a small object with the board on top. The weight of the board should keep the socket or chip completely seated. Then tack down a couple of corner pins and recheck orientation and seating. Then finish soldering the rest of the pins.

Take your time and enjoy the process, double checking orientation of devices as you go. The red or blue arrows indicate places to pay special attention when placing components.

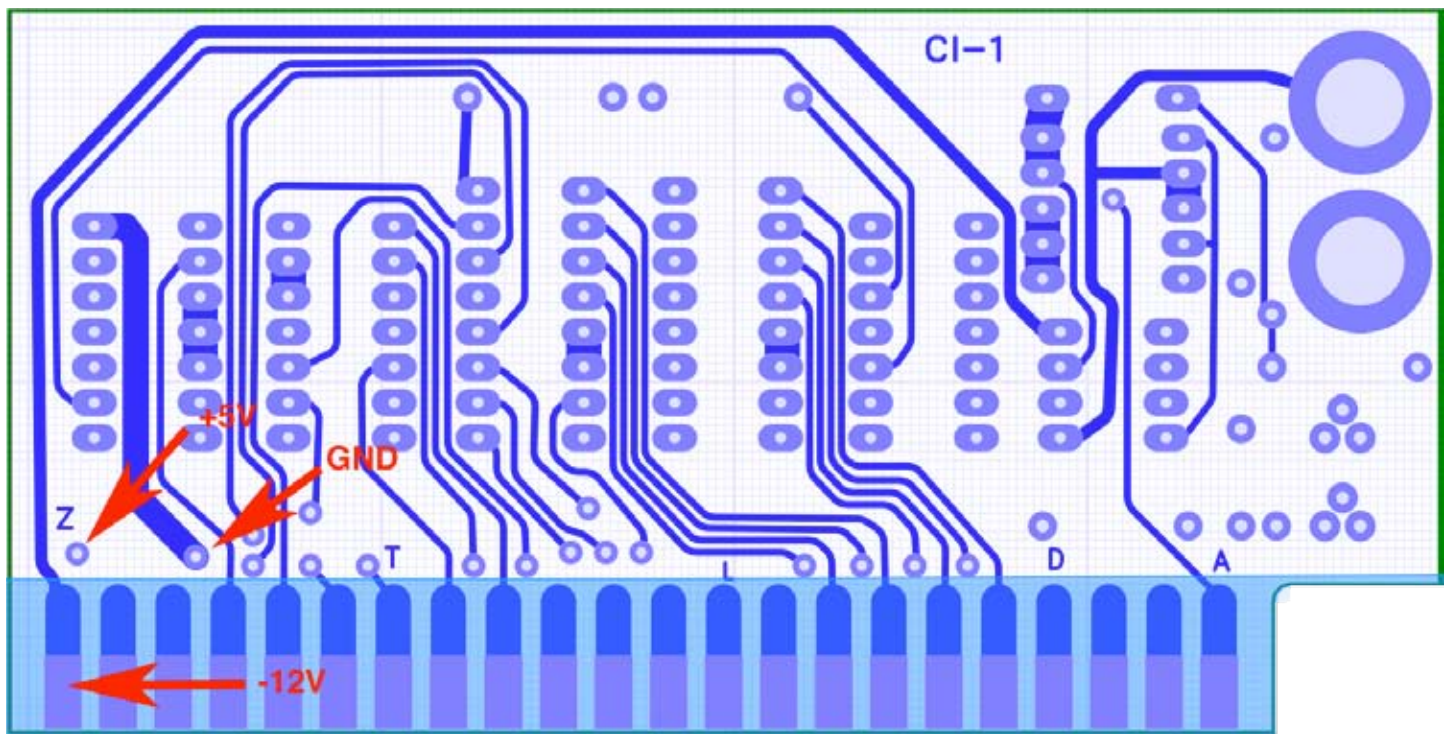

back side of board

### 2. Check for Power and Ground Shorts on PCB

Easiest way to do this is to use an ohm-meter to make sure that there is no connection between +5 volts, -12 volts and ground. The Ohm meter should show no connections between any of these nets. A convenient place to use to check for shorts, is this area on the back of the board (red arrows above).

### 3. Solder in All Components Except 1/8" Phono Jacks

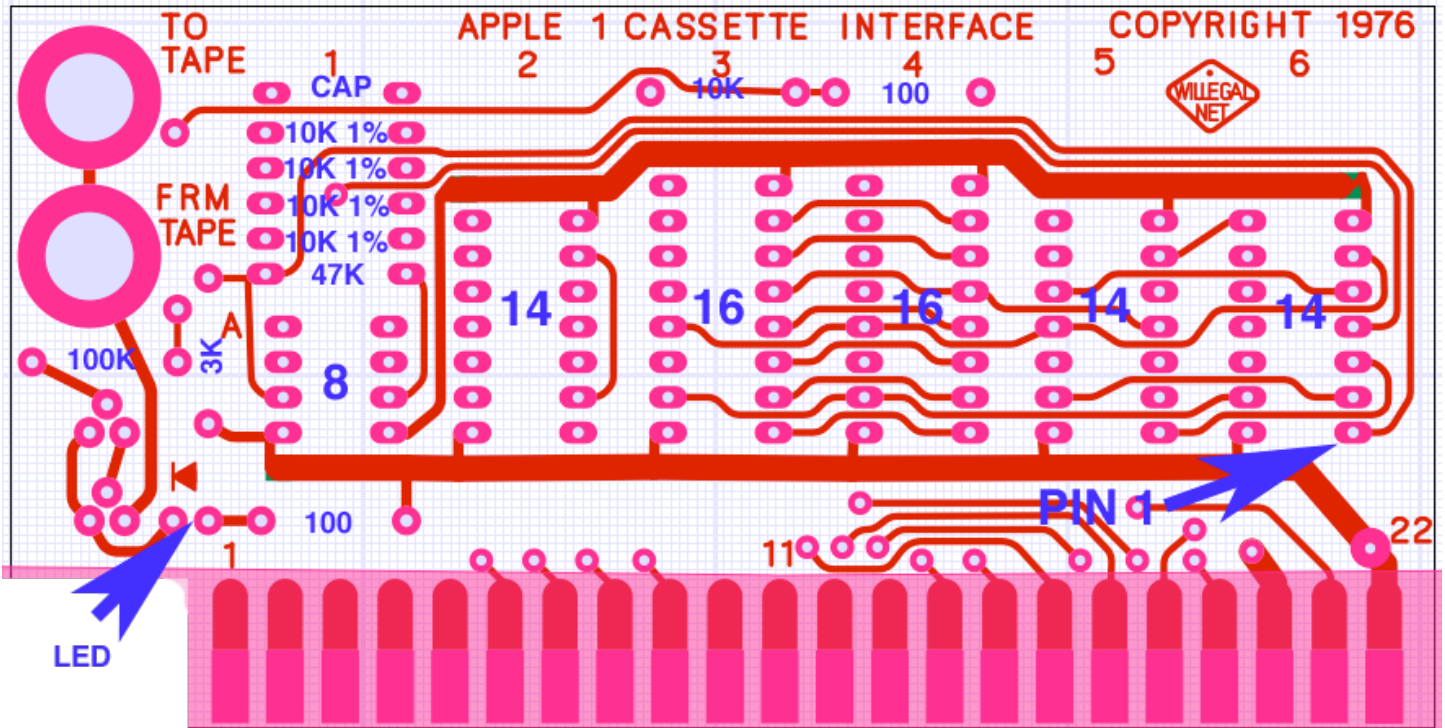

front view of board (components are mounted on front side of board)

PART	DESCRIPTION	QUANTITY	COMPLETE
16 pin socket	A-3 and A-4 - pin 1 toward gold finger edge	2	
14 pin socket	A-2, A-5, A-6 - pin 1 toward gold finger edge	3	
8 pin socket	A-1 - pin 1 toward gold finger edge	1	
capacitor	Input coupling capacitor - topmost device in row of components at A-1. Use .1uF (104) capacitor for better read reliability. Use .01uF (103) capacitor to exactly replicate original design.	1	
100 ohm	brown-black-brown Top of row at A4	2	
100 ohm	brown-black-brown Next to gold fingers in row A1		
3K ohm	orange-black-red Vertically mounted - left of 8 pin dip in row A-1	1	
10K resistor	brown-black-orange-gold Top of row at A-3	1	
10K 1% resistor	brown-black-orange-black-brown Four in a row below cap in row A-1	4	
47K resistor	yellow-violet-orange Just above 8 pin dip in row A-1.	1	
100K resistor	brown-black-yellow just below two 1/8" jacks	1	
MPS3704	Below two 1/8" jacks - flat side toward top of board (middle pin goes in hole closer to top of board)	2	
RED LED	Long lead (anode) on right	1	

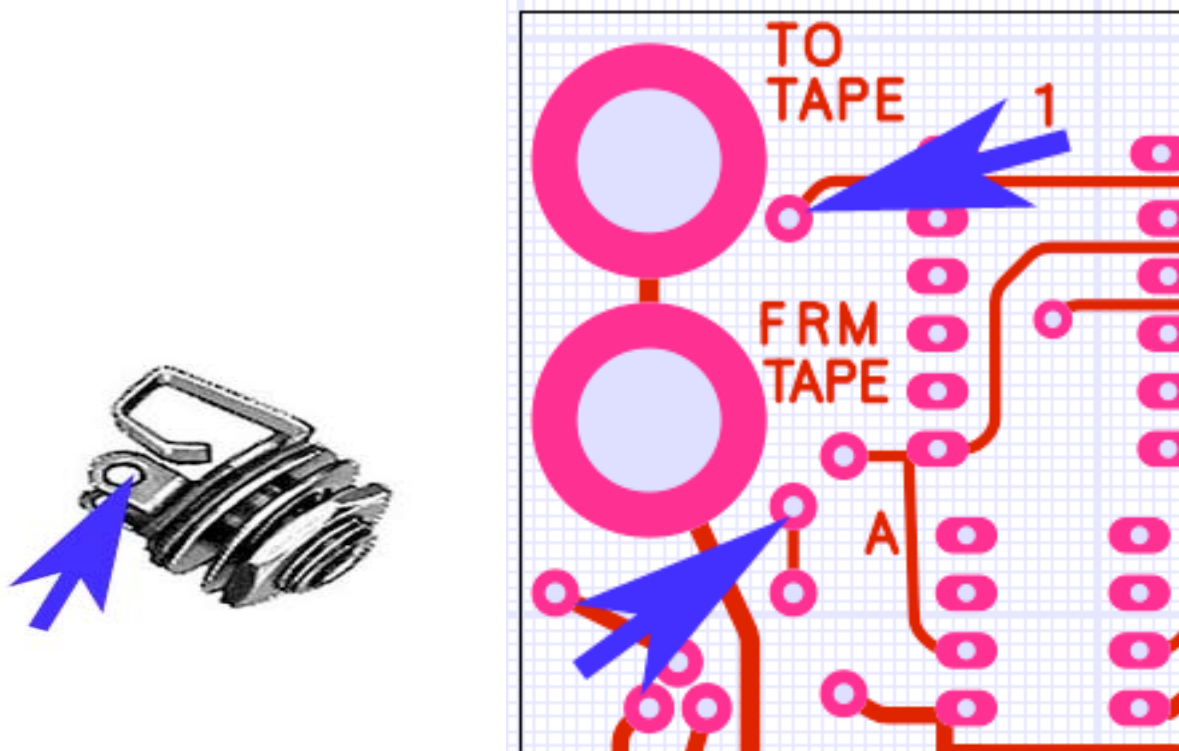

#### 4. Install 1/8" Phono Jacks

After mounting the jacks, a short wire must be connected from tab on jack to PCB hole to connect read and write circuits to the jacks. See the illustrations above for locations.

PART	DESCRIPTION	QUANTITY	COMPLETE
Read and Write Jacks	The jack is mounted with the receptacle facing the front of the board (the same side as the components). Screw on nut and with washers on each side of board. Ground is through this connection. Cut two short lengths of wire that are long enough to reach from tab on jack to hole in PCB. Strip ends of short wire. From the back of the board, solder one end to tab on jack and the other to the appropriate hole in the PCB.	2	

#### 5. Recheck for Power and Ground Shorts on PCB

Easiest way to do this is to use an ohm-meter to make sure that there is no direct connection between +5 volts, -12 volts and ground. With the resistors now soldered in, you should note about 5K ohms resistance between +5 volts and ground. -12 volts should have no connectivity with either +5 volts or ground.

## 6. Install ICs

PART	DESCRIPTION	QUANTITY	COMPLETE
LM311	8 Pin Socket at A-1. Pin 1 toward gold fingers	2	
74LS74	14 Pin Socket at A-2. Pin 1 toward gold fingers. Use 74LS74 for original performance. Because of the floating inputs, a replacement 7474 is provided as an optional substitute part and should provide for more reliable operation. A 7474 with floating inputs has more predictable behavior than a 74LS74.		
PROM A-3	16 Pin Socket at A-3. Pin 1 toward gold fingers. Prom is printed with "APPLE A-3" on top of the package and has an A3 label on the bottom.		
PROM A-4	16 Pin Socket at A-4. Pin 1 toward gold fingers. Prom is printed with "APPLE A-4" on top of the package and has an A4 label on the bottom.		
74LS02	14 Pin Socket at A-5. Pin 1 toward gold fingers.		
74LS10	14 Pin Socket at A-6. Pin 1 toward gold fingers.		

## 7. Clean PCB of Rosin and By-products of Soldering

Once soldering is complete, clean the back of PCB of excess flux and rosin. 90% or higher isopropyl alcohol. IPA will dissolve soldering resin. Spray it on the back of the board and lightly scrub with a very soft brush that will not scratch the surface of the PCB. Soak up the IPA and contaminates with a clean soft cloth before the IPA evaporates in order to remove the by products of soldering. Let dry overnight. Position a fan to blow over the board to make sure that all remaining moisture evaporates.

I have also discovered that "Windex" window cleaner can help remove the by-products from the soldering job. Removing contaminates is important as many kinds of rosins are corrosive.

## 8. Check Board for Solder Bridges and Cold Solder Joints

While the board is drying, you should carefully check your work for bad solder joints and solder bridges.

## Chapter 3 – Installation, Operation and Help

### 1. Installation and Operation

Completely read and understand the original Apple Cassette Interface Manual reproduced in appendix C for installation and operation instructions.

### 2. Troubleshooting and Help

A good job of soldering the components into place should eliminate most if not all trouble. First step, in case of trouble, should be to check for bad solder joints or bridges.

Refer to my Apple II repair page at [www.willegal.net](http://www.willegal.net) for some general troubleshooting hints.

Feel free to send email to: [mike@willegal.net](mailto:mike@willegal.net) if you run into difficulties.

•

## ***Appendix A - Using an iPod With the ACI***

An iPod may be used in place of a cassette player with the ACI. Almost any iPod can be used for loading programs with the same cable that is used for reading from a cassette player. Programs must be put into AIFF format prior to loading. I have listed several programs already in that format on this web page:

<http://www.willegal.net/appleii/apple1-software.htm>

This same page has the source code for a UNIX shell program that will convert programs in Apple monitor format into AIFF files, so that you can convert your own programs to be loaded from a iPod.

Writing to the iPod requires an iPod that supports microphone input, a special cable and an iPad application that uses a lossless recording format. A detailed writeup on the process can be found here.

<http://www.apple1notes.com/Home/Notes.html>

## ***Appendix B Replica 1 Notes***

The ACI has been tested and will work fine with a Briel Computer Systems Replica 1. However because the ACI requires -12volts, the Replica 1 must be powered by an ATX power supply. The Achatz replica does not have a provision for -12 volts, so the ACI will not work with that system.

## ***Appendix C - Apple's Original ACI Manual***

Appendix C is a digitized reproduction of the original eight page Apple Cassette Interface manual. Fonts and layout are similar to the original, but not exact reproductions. Disregard warranty, address, phone number information - this data is left in place, so the complete manual is preserved.

The manual contains accurate and useful information for operation of the ACI. It is my opinion is that the reliability of the ACI is not as good as the manual suggests, especially with the stock .01uF capacitor in place. Unlike what the manual indicates, performance with various cassette recorders can vary from not functional to works pretty well.

## ***Appendix D – ACI Source Code Listing***

Appendix D is the source code listing for the 256 byte PROM bank that exists on the ACI card.





# APPLE-II CASSETTE INTERFACE



# INTRODUCTION

The Apple Cassette Interface [ACI] is a peripheral device for the Apple Computer which enables the user to store and retrieve information (data and programs) using a standard audio grade cassette recorder. The ACI attaches directly to the Apple Computer and jacks are provided on the ACI board to connect to the cassette recorder. The ACI reads and writes data at the rate of approximately 1500 baud (depending upon the data). All the ACI timing is done in software, resulting in extreme accuracy, no adjustments, and consistency between units.

## TAPE RECORDERS & TAPE

Almost any cassette recorder will work well with the ACI. As a recommendation, we have found the least expensive (under \$40) Panasonic to be very reliable and of good quality, although it is not equipped with a tape counter, which is useful (though not essential) for locating files within a tape. (An alternative method of discerning files is to record a voice identification between files.)

Among the 'under \$25' cassette recorders there may be variations in head alignment and internal electronics,

resulting in the inability to accurately read a tape that has been recorded on a different machine. However, if the same unit is used for both recording and reading, even the cheapest of cassette recorders will work reliably.

Most tapes available in the \$2-\$4 category work well for data storage. You may experience an occasional tape which 'loses bits' which is caused by severe oxide thickness variations on the tape and cannot be corrected. Special leaderless tapes need not be used as the ACI automatically transmits a ten second 'header' of all ones before transmitting the data, which insures that the leader will have passed.

## JUMPERS

For operation of the ACI, a permanent jumper must be placed between 'R' and 'C' in the block select area of the main board (B9,10). This jumper from 'R' which is connected to enable the ACI, to 'C' selects the ACI when the 12th 4K block ('C') is addressed.

Also, for running Apple Basic in the 2nd 4K band of on-board memory, it is necessary to break the solder jumper between 'W' and 'I' and then jumper 'W' to 'E.' This moves the 2nd 4K bank from the 'I' block to the 'E' block, which is where Apple Basic resides.

## INSTALLATION

Install the ACI board into the connector on the main board with the components on the ACI board facing away from the main board (the jacks to the edge of the main board). SEE FIGURE 1. The system power should be OFF whenever installing or removing the ACI board.

Install cables from the ACI jack marked "TO TAPE" to the recorder microphone input and from the ACI jack marked "FROM TAPE" to the recorder earphone output. One cable can be appropriately switched between the two paths if necessary.

## USING THE ACI

The Cassette program is contained in two PROMS on the ACI board and runs at C100. When entered, the program should echo an "\*" The format for specifying the memory address ranges to be either stored (write) or deposited into (read) is identical to the standard monitor format: **Beginning . End** , suffixed with either a 'W' (write) or an 'R' (read). Execution will start following a carriage return (CR). The cassette program will return control to the system monitor upon completion of a read or write. Illegal characters (or the absence of characters) in the address line will return control to the system monitor without execution, following a carriage return.

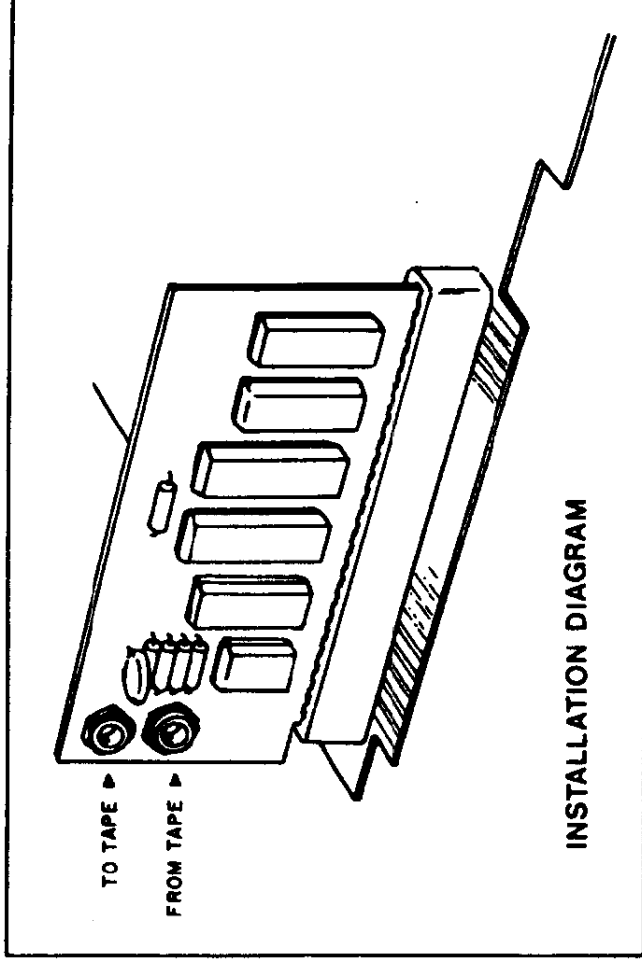

## MULTIPLE RANGES

The ACI is capable of reading and writing multiple address ranges. The format is: **A.BW C.DW (R for read)**. Again, spaces are ignored. The ACI will write a ten second header, the first range, another header and the second range. **100.200W 300.500W** will write a header, 100 in 200, a second header, and 300 to 500. When reading a multiple range tape. **YOU MUST USE THE SAME ADDRESS INCREMENTS AS WERE USED IN WRITING THE TAPE**. This does not mean the same absolute addresses, but rather the same increments.

The procedure for reading from a tape into memory is:  
**C100R (RET)** This enters the cassette program and should echo an “\*”

**E000 . EFFFFR** This will load the tape data into memory locations E000.EFFF . ‘R’ denotes a read, and spaces are ignored. [Don’t hit ‘return’ yet.]

### **Start the Tape**

**Hit ‘RETURN’** A carriage return will start execution of a read. The ‘return’ can be hit immediately, however, it must be hit within 5 seconds after the start of tape motion.

When the last location (EFFF in this example) has been loaded, the program will print a ‘/’ and return control to the monitor.

The procedure for a write is identical except the suffix ‘W’ is substituted for ‘R’ in the address line. For both read and write, the tape should always be moving before hitting the RETURN.

## **LEVEL**

The Cassette recorder output level should be set to where the LED on the ACI is just fully lit. Increase the level from zero until the LED glows fully. If you experience a bad read, try it a LITTLE higher. The LED indicator is operational even when the cassette program is not executing, and the level should be set prior to reading a tape, **NOT** during the reading of a tape.

## **SPEED**

The ACI uses the technique of recording a whole cycle of either a 1kHz cycle (representing a ‘one’ data bit) or a 2 kHz cycle (representing a ‘zero’ data bit). Therefore, with an average data mix of one’s and zero’s, data will be recorded at 1500 baud. A ten second header of all ones will automatically be recorded on the tape prior to memory data. This is to insure that the clear leader portion of the tape will have passed. See schematic for further details.

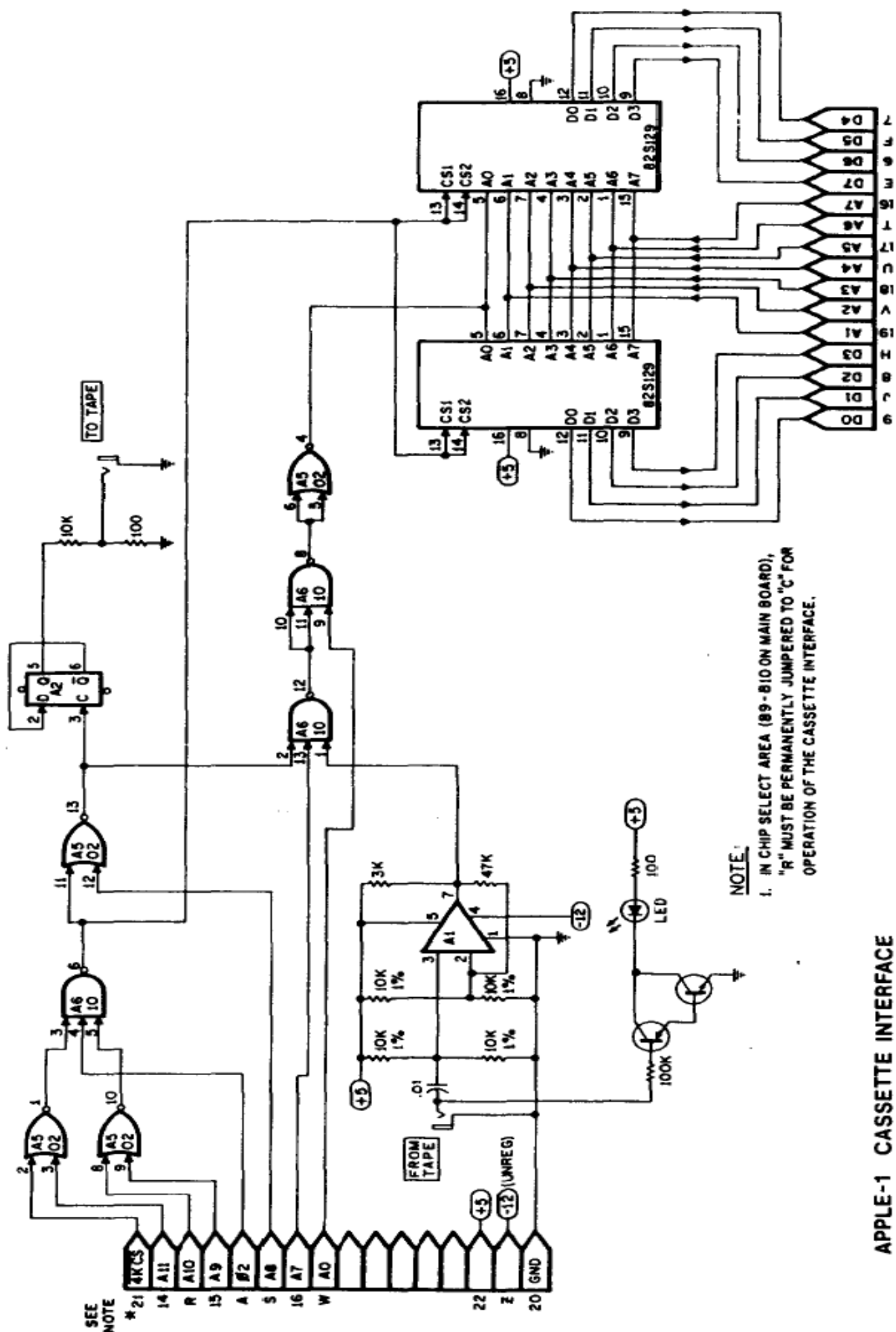

SEE NOTE

\*21

**NOTE:**

1. IN CHIP SELECT AREA (B9-B10 ON MAIN BOARD), "R" MUST BE PERMANENTLY JUMPED TO "C" FOR OPERATION OF THE CASSETTE INTERFACE.

APPLE-1 CASSETTE INTERFACE

# WARRANTY

Apple Computer Company hereby warrants each of its products, and all components therein contained, to be free from defects in materials and/or workmanship for a period of thirty (30) days from date of purchase. In the event of the occurrence of malfunction, or other indication of failure attributable directly to faulty workmanship and/or material, then, upon return of the product to the Apple Computer Company at 770 Welch Road, Palo Alto, California 94304 (postage prepaid), the Apple Computer Company will, at its option, repair or replace said products or components thereof, to whatever extent Apple Computer Company shall deem necessary, to restore said product to proper operating condition. All such repairs or replacements shall be rendered by Apple Computer Company without charge to the customer.

The responsibility for the failure of any Apple Computer product, or component thereof, which, at the discretion of the Apple Computer Company, shall have resulted either directly or indirectly from accident, abuse, or misapplication of the product, shall be assumed by the customer and the Apple Computer Company shall assume no liability as a consequence of such events under the terms of this warranty.

While every effort, on the part of Apple Computer Company, is made to provide clear and accurate technical instruction on the use, implementation, and application of its products, the Apple Computer Company shall assume no liability in events which arise from the application of such technical instruction, nor shall the Apple Computer Company be held liable for the quality, interconnection, or application of peripheral products, which may have been recommended by Apple Computer Company, but which have not been supplied as part of the product.

This warranty contains and embodies the limits of responsibility of the Apple Computer Company with regard to its products, and no other liability is expressed, implied, or should be assumed by the purchaser, and in no event shall the Apple Computer Company be held liable for the loss of time, effort, or transportation costs, nor for loss of potential profits or other consequential losses which might arise from the purchase, assembly, use, application, or subsequent sale of the products of Apple Computer Company, nor from any instructions and/or mechanical information thereto related.

**APPLE COMPUTER COMPANY**

**770 Welch Road, Suite 154**

**Palo Alto, California 94304**

**Phone:(415) 326-4248**



```

1 c200                                PROCESSOR 6502
2 c200 ????                            LIST    ON
3 c200 ????                            ;-----
4 c200 ????                            ;
5 c200 ????                            ; The WOZ Apple Cassette Interface for the Apple 1
6 c200 ????                            ; Written by Steve Wozniak somewhere around 1976
7 c200 ????                            ;
8 c200 ????                            ;-----
9 c200 ????
10 c100                                ORG    $C100
11 c100
12 c100                                ;-----
13 c100                                ; Memory declaration
14 c100                                ;-----
15 c100
16 c100    00 24    HEX1L    EQU    $24        ;End address of dump block
17 c100    00 25    HEX1H    EQU    $25
18 c100    00 26    HEX2L    EQU    $26        ;Begin address of dump block
19 c100    00 27    HEX2H    EQU    $27
20 c100    00 28    SAVEINDEX EQU    $28        ;Save index in input buffer
21 c100    00 29    LASTSTATE EQU    $29        ;Last input state
22 c100
23 c100    02 00    IN        EQU    $0200      ;Input buffer
24 c100    c0 00    FLIP     EQU    $C000      ;Output flip-flop
25 c100    c0 81    TAPEIN   EQU    $C081      ;Tape input
26 c100    d0 10    KBD      EQU    $D010      ;PIA.A keyboard input
27 c100    d0 11    KBDCR   EQU    $D011      ;PIA.A keyboard control register
28 c100    ff 1a    ESCAPE   EQU    $FF1A      ;Escape back to monitor
29 c100    ff ef    ECHO     EQU    $FFEF      ;Echo character to terminal
30 c100
31 c100                                ;-----
32 c100                                ; Constants
33 c100                                ;-----
34 c100
35 c100    00 8d    CR        EQU    $8D        ;Carriage Return
36 c100    00 9b    ESC      EQU    $9B        ;ASCII ESC
37 c100
38 c100                                ;-----
39 c100                                ; Let's get started
40 c100                                ;-----
41 c100
42 c100    a9 aa    WOZACI    LDA    #$AA        ;Print the Tape prompt ""*""
43 c102    20 ef ff                JSR    ECHO
44 c105    a9 8d                LDA    #CR        ;And drop the cursor one line
45 c107    20 ef ff                JSR    ECHO
46 c10a
47 c10a    a0 ff                LDY    #-1        ;Reset the input buffer index
48 c10c    c8      NEXTCHAR    INY
49 c10d    ad 11 d0    KBDWAIT  LDA    KBDCR      ;Wait for a key
50 c110    10 fb                BPL    KBDWAIT    ;Still no key!
51 c112
52 c112    ad 10 d0                LDA    KBD        ;Read key from keyboard
53 c115    99 00 02            STA    IN,Y        ;Save it into buffer
54 c118    20 ef ff                JSR    ECHO        ;And type it on the screen
55 c11b    c9 9b                CMP    #ESC
56 c11d    f0 e1                BEQ    WOZACI      ;Start from scratch if ESC!
57 c11f    c9 8d                CMP    #CR
58 c121    d0 e9                BNE    NEXTCHAR    ;Read keys until CR
59 c123
60 c123    a2 ff                LDX    #-1        ;Initialize parse buffer pointer
61 c125

```

```

62 c125 ;-----
63 c125 ; Start parsing first or a new tape command
64 c125 ;-----
65 c125
66 c125 a9 00 NEXTCMD LDA #0 ;Clear begin and end values
67 c127 85 24 STA HEX1L
68 c129 85 25 STA HEX1H
69 c12b 85 26 STA HEX2L
70 c12d 85 27 STA HEX2H
71 c12f
72 c12f e8 NEXTCHR INX ;Increment input pointer
73 c130 bd 00 02 LDA IN,X ;Get next char from input line
74 c133 e9 d2 CMP #$D2 ;Read command? "R"
75 c135 f0 56 BEQ READ ;Yes!
76 c137 c9 d7 CMP #$D7 ;Write command? "W"
77 c139 f0 35 BEQ WRITE ;Yes! (note: CY=1)
78 c13b c9 ae CMP #$AE ;Separator? "."
79 c13d f0 27 BEQ SEP ;Yes!
80 c13f c9 8d CMP #CR ;End of line?
81 c141 f0 20 BEQ GOESC ;Escape to monitor! We're done
82 c143 c9 a0 CMP #$A0 ;Ignore spaces: " "
83 c145 f0 e8 BEQ NEXTCHR
84 c147 49 b0 EOR #$B0 ;Map digits to 0-9 "0"
85 c149 c9 0a CMP #9+1 ;Is it a decimal digit?
86 c14b 90 06 BCC DIG ;Yes!
87 c14d 69 88 ADC #$88 ;Map letter "A"- "F" to $FA-$FF
88 c14f c9 fa CMP #$FA ;Hex letter?
89 c151 90 ad BCC WOZACI ;No! Character not hex!
90 c153
91 c153 0a DIG ASL ;Hex digit to MSD of A
92 c154 0a ASL
93 c155 0a ASL
94 c156 0a ASL
95 c157
96 c157 a0 04 LDY #4 ;Shift count
97 c159 0a HEXSHIFT ASL ;Hex digit left, MSB to carry
98 c15a 26 24 ROL HEX1L ;Rotate into LSD
99 c15c 26 25 ROL HEX1H ;Rotate into MSD
100 c15e 88 DEY ;Done 4 shifts?
101 c15f d0 f8 BNE HEXSHIFT ;No! Loop
102 c161 f0 cc BEQ NEXTCHR ;Handle next character
103 c163
104 c163 ;-----
105 c163 ; Return to monitor, prints \ first
106 c163 ;-----
107 c163
108 c163 4c 1a ff GOESC JMP ESCAPE ;Escape back to monitor
109 c166
110 c166 ;-----
111 c166 ; Separating . found. Copy HEX1 to Hex2. Doesn't clear HEX1!!!
112 c166 ;-----
113 c166
114 c166 a5 24 SEP LDA HEX1L ;Copy hex value 1 to hex value 2
115 c168 85 26 STA HEX2L
116 c16a a5 25 LDA HEX1H
117 c16c 85 27 STA HEX2H
118 c16e b0 bf BCS NEXTCHR ;Always taken!
119 c170

```

```

120 c170 ;-----
121 c170 ; Write a block of memory to tape
122 c170 ;-----
123 c170
124 c170 a9 40 WRITE LDA #64 ;Write 10 second header
125 c172 20 cc c1 JSR WHEADER
126 c175
127 c175 88 WRNEXT DEY ;Compensate timing for extra work
128 c176 a2 00 LDX #0 ;Get next byte to write
129 c178 a1 26 LDA (HEX2L,X)
130 c17a
131 c17a a2 10 LDX #8*2 ;Shift 8 bits (decremented twice)
132 c17c 0a WBITLOOP ASL ;Shift MSB to carry
133 c17d 20 db c1 JSR WRITEBIT ;Write this bit
134 c180 d0 fa BNE WBITLOOP ;Do all 8 bits!
135 c182
136 c182 20 f1 c1 JSR INCADDR ;Increment address
137 c185 a0 1e LDY #30 ;Compensate timer for extra work
138 c187 90 ec BCC WRNEXT ;Not done yet! Write next byte
139 c189
140 c189 a6 28 RESTIDX LDX SAVEINDEX ;Restore index in input line
141 c18b b0 98 BCS NEXTCMD ;Always taken!
142 c18d
143 c18d ;-----
144 c18d ; Read from tape
145 c18d ;-----
146 c18d
147 c18d 20 bc c1 READ JSR FULLCYCLE ;Wait until full cycle is detected
148 c190 a9 16 LDA #22 ;Introduce some delay to allow
149 c192 20 cc c1 JSR WHEADER ; the tape speed to stabilize
150 c195 20 bc c1 JSR FULLCYCLE ;Synchronize with full cycle
151 c198
152 c198 a0 1f NOTSTART LDY #31 ;Try to detect the much shorter
153 c19a 20 bf c1 JSR CMPLEVEL ; start bit
154 c19d b0 f9 BCS NOTSTART ;Start bit not detected yet!
155 c19f
156 c19f 20 bf c1 JSR CMPLEVEL ;Wait for 2nd phase of start bit
157 c1a2
158 c1a2 a0 3a LDY #58 ;Set threshold value in middle
159 c1a4 a2 08 RDBYTE LDX #8 ;Receiver 8 bits
160 c1a6 48 RDBIT PHA
161 c1a7 20 bc c1 JSR FULLCYCLE ;Detect a full cycle
162 c1aa 68 PLA
163 c1ab 2a ROL ;Roll new bit into result
164 c1ac a0 39 LDY #57 ;Set threshold value in middle
165 c1ae ca DEX ;Decrement bit counter
166 c1af d0 f5 BNE RDBIT ;Read next bit!
167 c1b1 81 26 STA (HEX2L,X) ;Save new byte
168 c1b3
169 c1b3 20 f1 c1 JSR INCADDR ;Increment address
170 c1b6 a0 35 LDY #53 ;Compensate threshold with workload
171 c1b8 90 ea BCC RDBYTE ;Do next byte if not done yet!
172 c1ba b0 cd BCS RESTIDX ;Always taken! Restore parse index
173 c1bc
174 c1bc 20 bf c1 FULLCYCLE JSR CMPLEVEL ;Wait for two level changes
175 c1bf 88 CMPLEVEL DEY ;Decrement time counter
176 c1c0 ad 81 c0 LDA TAPEIN ;Get Tape In data
177 c1c3 c5 29 CMP LASTSTATE ;Same as before?
178 c1c5 f0 f8 BEQ CMPLEVEL ;Yes!
179 c1c7 85 29 STA LASTSTATE ;Save new data
180 c1c9
181 c1c9 c0 80 CPY #128 ;Compare threshold
182 c1cb 60 RTS
183 c1cc

```

```

184 c1cc ;-----
185 c1cc ; Write header to tape
186 c1cc ;
187 c1cc ; The header consists of an asymmetric cycle, starting with one phase of
188 c1cc ; approximately (66+47)x5=565us, followed by a second phase of
189 c1cc ; approximately (44+47)x5=455us.
190 c1cc ; Total cycle duration is approximately 1020us ~ 1kHz. The actual
191 c1cc ; frequency will be a bit lower because of the additional workload between
192 c1cc ; the two loops.
193 c1cc ; The header ends with a short phase of (30+47)x5=385us and a normal
194 c1cc ; phase of (44+47)x5=455us. This start bit must be detected by the read
195 c1cc ; routine to trigger the reading of the actual data.
196 c1cc ;-----
197 c1cc
198 c1cc      86 28  WHEADER      STX      SAVEINDEX      ;Save index in input line
199 c1ce      a0 42  HCOUNT      LDY      #66              ;Extra long delay
200 c1d0      20 e0 c1  JSR      WDELAY      ;CY is constantly 1, writing a 1
201 c1d3      d0 f9              BNE      HCOUNT      ;Do this 64 * 256 time!
202 c1d5      69 fe              ADC      #-2           ;Decrement A (CY=1 all the time)
203 c1d7      b0 f5              BCS      HCOUNT      ;Not all done!
204 c1d9      a0 1e              LDY      #30           ;Write a final short bit (start)
205 c1db ;
206 c1db ;-----
207 c1db ; Write a full bit cycle
208 c1db ;
209 c1db ; Upon entry Y contains a compensated value for the first phase of 0
210 c1db ; bit length. All subsequent loops don't have to be time compensated.
211 c1db ;-----
212 c1db
213 c1db      20 e0 c1  WRITEBIT      JSR      WDELAY      ;Do two equal phases
214 c1de      a0 2c              LDY      #44           ;Load 250us counter - compensation
215 c1e0
216 c1e0      88          WDELAY      DEY              ;Delay 250us (one phase of 2kHz)
217 c1e1      d0 fd              BNE      WDELAY
218 c1e3      90 05              BCC      WRITE1        ;Write a '1' (2kHz)
219 c1e5
220 c1e5      a0 2f              LDY      #47           ;Additional delay for '0' (1kHz)
221 c1e7      88          WDELAY0      DEY              ; (delay 250us)
222 c1e8      d0 fd              BNE      WDELAY0
223 c1ea
224 c1ea      bc 00 c0  WRITE1      LDY      FLIP,X        ;Flip the output bit
225 c1ed      a0 29              LDY      #41           ;Reload 250us cntr (compensation)
226 c1ef      ca              DEX              ;Decrement bit counter
227 c1f0      60              RTS
228 c1f1
229 c1f1 ;-----
230 c1f1 ; Increment current address and compare with last address
231 c1f1 ;-----
232 c1f1
233 c1f1      a5 26  INCADDR      LDA      HEX2L        ;Compare current address with
234 c1f3      c5 24              CMP      HEX1L        ; end address
235 c1f5      a5 27              LDA      HEX2H
236 c1f7      e5 25              SBC      HEX1H
237 c1f9      e6 26              INC      HEX2L        ;And increment current address
238 c1fb      d0 02              BNE      NOCARRY      ;No carry to MSB!
239 c1fd      e6 27              INC      HEX2H
240 c1ff      60          NOCARRY      RTS
241 c200
242 c200 ;-----
243 c200

```