

Apple 1 Mimeo Computer Assembly and Bring Up Guide

By Mike Willegal

www.willegal.net

revision 1.1

CAUTION!!!

This computer was designed by a hobbyist for hobbyist in the new hobby of personal computing. Safety standards were nonexistent or ignored. The designer assumed that the purchaser had either electronics knowledge or a access to a group of friends that could provide this knowledge and guidance. This is an accurate reproduction. I encourage you to return the kit for a full refund, if you have neither electronics knowledge or friends that can help you. Connection of the transformers to your house wiring is left to you. There are rudimentary instructions in the Apple-1 Operation Manual. If you don't feel comfortable with this task, assume that you don't have the qualifications to build this kit and either find some help, or return the kit for a full refund.

CAUTION NUMBER 2!!!

There are many new old stock components in this kit that may fail prematurely and unexpectedly. Failure modes are unpredictable and may result in sparks and fire. Do not leave this computer running without someone present to monitor operation. In the event that parts fail on your board, please let us know, so we can inform other users of the event and possibly find alternative parts, in case a trend across several boards is detected.

Forward

When completed, your Apple 1 Mimeo computer kit will become an accurate reproduction of one of the most famous computers in the short history of digital computing. The Apple 1 was the first product, built and marketed by Apple Computer. The circuitry was designed and a prototype built by Steve Wozniak, prior to the creation of Apple Computer. As Apple was formed, the circuitry designed by Steve Wozniak was turned into a PCB layout by Atari employee, Howard Cantin.

Approximately 200 originals were sold by Apple, and it is unknown how many still exist. Some people think that the number may be as few as 20. Because of the historical significance and rarity, they are very valuable. An original example, recently sold for over \$50,000. Extensive research and effort has been extended in order to make this reproduction as close to the original in as many respects as possible. We have consulted with owners of original Apple 1s, as well as the builders of several replicas in the quest to make this computer as faithful to the original as possible. Currently, there is no data available on the exact routes of traces under chips and certain portions of the silk screen that lies beneath components. Understandably, owners of original systems could not be encouraged to X-ray or dismantle their units in order to uncover this information. The routes and silk screen in these areas are placed based on common sense and our experience with the Apple II rev 0, which was also laid out by Howard Cantin.

Parts for your kit were obtained after exhaustive searches, often extending to Europe and Asia. Some components that come with the kit are new, old stock parts that are as old or older than the original Apple 1s. A few parts are new production parts made by the original vendors. Most parts lie somewhere in between these extremes. All digital parts are of the same logic family that was originally specified. Note that the original Apple 1 was most likely made in two batches, with some parts coming from different sources in the different batches, with some overlap as stocks of existing inventories were used up, before transitioning to new stock. Often parts on original Apple 1s were replaced after failures or during modifications.

We are working on documenting known original Apple 1s and plan to provide web pages in which you can compare the parts on your computer to the original. A few adventurous (perhaps crazy) soles are attempting to find stocks of original parts, with date codes as close to those used by the original as possible. If you are interested in this effort, join the fun at <http://apple-1.org>.

Chapter 1 – Assemble Components, Tools, and Equipment

1. Recommended Tools and Equipment

- Quality soldering station - I use a Weller WES51. Whatever you use, I recommend that it has some kind of temperature controlled tip. This will help prevent damage to the PCB when soldering
- Solder - use quality solder - thinner solder is vastly easier to work with than fat solder. The fat stuff sold at hardware stores is not suitable for these sort of electronics projects
- Wire cutters – for trimming component lead
- Razor saw – for trimming ears off of edge connector
- Your favorite PCB cleaning agent - Isopropyl Alcohol will dissolve many kinds of soldering resin. Windex will also help with cleaning PCBs
- Ohm meter - to check for good connections and shorts
- Logic probe or oscilloscope – handy if you are having trouble with bring up
- Apple 1 Operations Manual – PDF copy of original is available at: <http://www.applefritter.com/taxonomy/term/229,142>
- Apple 1 schematics – The Apple-1 Operation Manual schematics are close to actual layout, but check my web pages for several differences between the operation manual and actual board

2. Additional Components (not included)

- ASCII keyboard - currently the only reliable source is from surplus Apple IIplus systems found on eBay. I'm working on a PS/2 keyboard to ASCII interface converter, check my web site for availability.
- Locate a TV or monitor that supports video composite input and an appropriate video cable.
- You will need to provide connectors, fuse and wiring between the transformers and house wiring. The original Apple-1 Operation Manual has some basic information.

3. Read and Understand the Apple 1 Operations Manual.

- This is available online as a download from sources like <http://www.applefritter.com/taxonomy/term/229,142>

4. Expansion Options (not included)

- Cassette interface adaptor - some reproductions have been made over the past few years. When time becomes available, I'll be investigating getting some more built
- Cassette recorder and tapes – for saving and loading programs through the cassette interface board
- CFFA-1 – Compact flash adaptor - an excellent mass storage for your Apple 1

5. Compare Received Components With Parts List

Examine and identify all parts provided with the kit. For a few components, equivalent replacement parts may be shipped with your kit. In these cases, both names are listed in the PART column. The first part is the original part number used by Apple. Most IC's are organized on the anti-static foam in the same order as they are listed here (top to bottom, left to right). Memory may come in anti-static tubes.

PART	DESCRIPTION	QUANTITY	PRESENT
2513	char ROM	1	
8T97	bus driver	2	
MMI 3601	256x4 PROM (1 part labeled LSB, 1 part labeled MSB)	2	
2504v	shift register	7	
2519b	shift register	1	
6820	parallel interface adapter	1	
DS0025C	clock driver	1	
6502	processor	1	
7400	quad NAND gate	3	
7402	quad NOR gate	1	
7404	hex inverter	1	
7408	quad and gate	1	
7410	three input nand	2	
74123	dual one-shot	1	
74154	4:16 demux	1	
74157	2:1 selector	2	
74160	4 bit counter	1	
74161 (74161A)	4 bit counter	5	
74166	shift register	1	
74174	hex flip flop	1	
74175	quad flip flop	1	
7427	triple 3 input nor gates	1	
7432	quad or gate	1	
7450	2 input and gate	1	
74S257	2:1 selector	4	
MK4096	4kx1 DRAM	16	
NE555	cursor timer	1	
Parts (socketed)		61	
Types (socketed)		27	

PART	DESCRIPTION	QUANTITY	PRESENT
PCB	motherboard	1	
PART	DESCRIPTION	QUANTITY	PRESENT
Expansion Connector	44 pin connector	1	
Power Connector	6 pin connector	1	
Video Connector	4 pin connector	1	
Connector Terminals	for 18-24 AWG wire	10	
Power header	6 pin header	1	
Video header	4 pin header	1	
PART	DESCRIPTION	QUANTITY	PRESENT
Stancor P-8667	transformer for +12, -12, -5	1	
Stancor P-8380	transformer for +5	1	

PART	DESCRIPTION	QUANTITY	PRESENT
100 ohm pot	video adjust	1	
330 ohm	orange-orange-brown	1	
390 ohm	orange-white-brown	2	
1500 ohm	brown-green-red	1	
3000 ohm	orange-black-red	12	
7.5K ohm	voilet-green-red	6	
10K ohm	brown-black-orange	3	
27K ohm	red-violet-orange	1	
PART	DESCRIPTION	QUANTITY	PRESENT
.001uF capacitor	102	1	
.01uF capacitor	103	4	
.1uF capacitor	104 decoupling caps	17	
47pF cap	video - mica	1	
22uF	power supply caps - blue	5	
2400uf cap	+12, -12 power supplies	2	
5300uF cap	+5 power supply	1	
PART	DESCRIPTION	QUANTITY	PRESENT
1n914 diode	pseudo or gate	4	
1N4001 diode	rectifier +12, -12 volts	4	
MR500/A14F	(either A14F or MR500 were used used)rectifier +5 volts	4	
PART	DESCRIPTION	QUANTITY	PRESENT
MPS3704	video output transistor	1	
PART	DESCRIPTION	QUANTITY	PRESENT
Crystal	clock source	1	
PART	DESCRIPTION	QUANTITY	PRESENT
LM323K	+5 volt regulator	1	
LM340 MP-12 (LM7812)	+12 volt regulator	1	
LM320 MP-12 (LM7912)	-12 volt regulator	1	
LM320 MP-5 (LM7905)	-5 volt regulator	1	
heatsink	for LM323K	1	
screws	for LM323K	2	
nuts	for LM323K	2	
heatsink grease	for LM323K	1	
PART	DESCRIPTION	QUANTITY	PRESENT
16 pin socket		42	
14 pin socket		12	
8 pin socket		1	
24 pin socket		2	
40 pin socket		2	
Types (soldered)		42	
Parts (soldered)		160	

Types (total)	69
Parts (total)	221

Chapter 2 – Solder In Sockets and Components

1. Remove Card Edge Connector

This connector may have been mounted on the board during shipment to prevent damage to the pins during shipping. You can carefully remove the connector for now, as it will be easier to solder in the sockets without the connector present. Set the connector in a safe place where the pins will not be damaged. The connector will be soldered in later on.

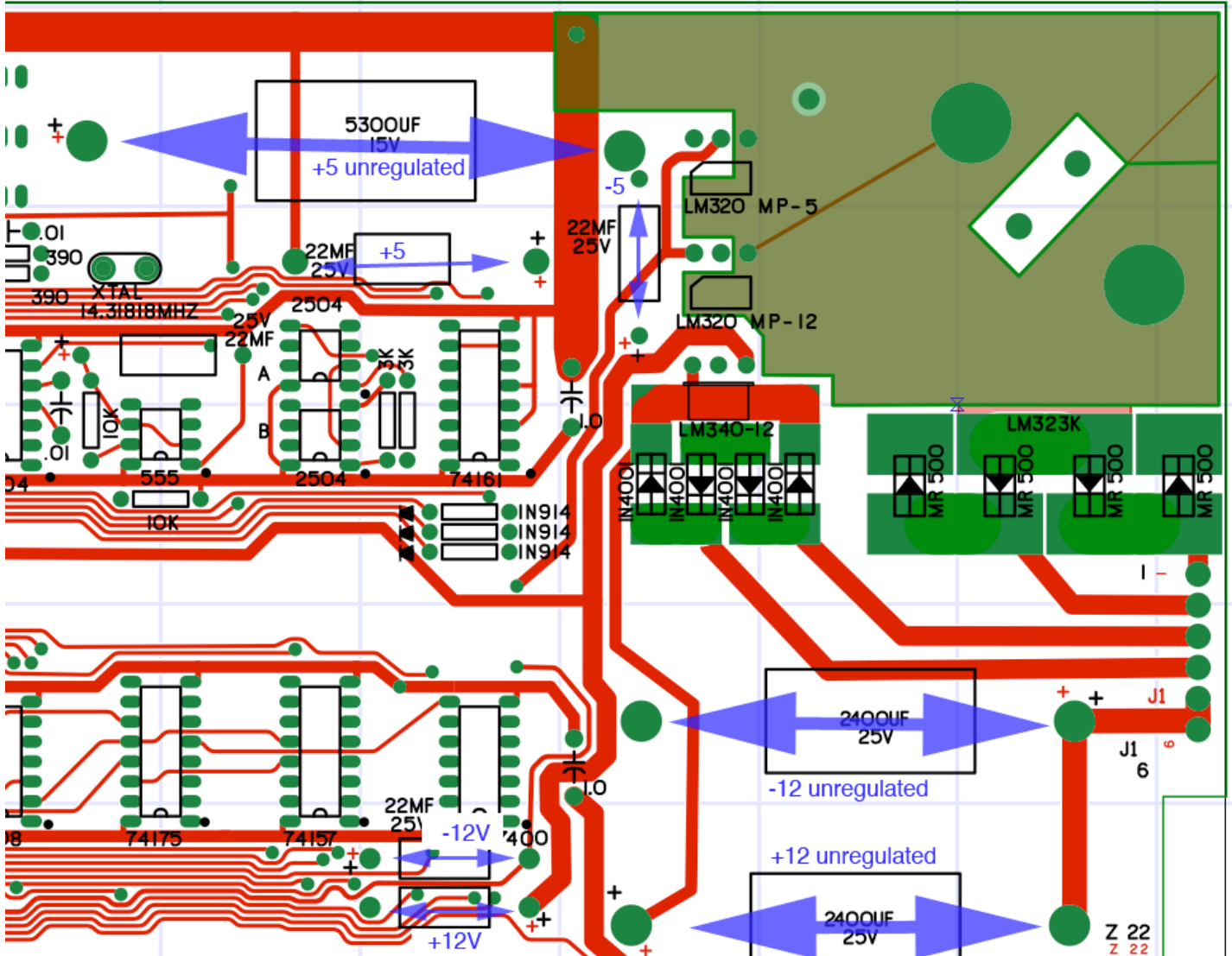

2. Check for Power and Ground Shorts

Easiest way to do this is to use an ohm-meter to make sure that there is no connection between power and ground in any of the power supply nets. Start with the unregulated power supply nets, +5V, +12V and -12V. There is no unregulated -5V net, as input to the -5V regulator is from the -12V regulated supply. The easiest way to check for shorts is by checking for shorts between pads of large capacitors. This is shown in the image above by the large double ended arrows.

Next check for shorts in the regulated power supply nets, +5V, -5V, +12V and -12V. The pads of smaller capacitors can be used for this. These indicated in the image, above, by the smaller double ended arrows.

3. Sockets

The key thing here is to check orientation and make sure that you don't put a 14 pin socket in a location for a 16 pin socket. Start with the biggest sockets, since you can't put a big socket in a location for a smaller one. Make sure that the socket is oriented correctly with pin 1 of the socket near to the white dot on the PCB.

Make sure the sockets are fully seated. I accomplish this by resting the socket upside down on a small object with the board on top. The weight of the board should keep the socket completely seated. Then tack down a couple of corner pins and recheck orientation and seating. Then finish soldering the rest of the pins.

Don't try to do too much in one sitting. Soldering a couple of dozen sockets in an evening is plenty.

4. Solder the 2, 40 Pin Sockets

Pin 1 is to the right; make sure you orient the sockets correctly.

PART	LOCATION	DESCRIPTION	COMPLETE
40 pin socket	A-4	PIA - pin 1 to right	
40 pin socket	A-7	processor - pin 1 to right	

5. Solder the 2, 24 Pin Sockets

Pin 1 is to the right; make sure you orient the sockets correctly with pin 1 toward the right of the board.

PART	LOCATION	DESCRIPTION	COMPLETE
24 pin socket	B-9	74154 - pin1 to right	
24 pin socket	D-2	2513 - pin 1 to right	

6. Solder All 42, 16 Pin Sockets

I wouldn't attempt to do this many sockets in one sitting. After a couple of rows or when you get tired, take a break. Check orientation and solder corner pins. Before soldering remaining pins, double check seating and orientation.

PART	LOCATION	DESCRIPTION	COMPLETE
16 pin sockets	A-1, A-2	PROMS	
16 pin sockets	A-9, A-10	Data Bus Drivers	
16 pin sockets	A-11 to A-18	DRAM bank W (8 sockets)	
16 pin sockets	B-3	74123	
16 pin sockets	B-4	Keyboard Connector	
16 pin socket	B-5 to B-8	72257 (4 sockets)	
16 pin socket	B-11 to B-18	DRAM Bank X (8 sockets)	
16 pin socket	C-3	2519	
16 pin socket	C-4	74157	
16 pin sockets	C-7	74174	
16 pin socket	C-11(a&b)	2504 & DS00025 (2 chips in 1 socket)	
16 pin socket	C-13	74175	
16 pin sockets	C-14	74157	
16 pin sockets	D-1	74166	
16 pin socket	D4 (a&b), D5 (a&b)	2504 (4 chips in 2 socket)	
16 pin sockets	D-6	74160	
16 pin sockets	D-7 to D9	74161 (3 sockets)	
16 pin socket	D-11	74161	
16 pin socket	D14 (a&b)	2504 (2 chips in 1 socket)	
16 pin sockets	D-15	74161	

7. Solder the 12, 14 Pin Sockets

Make sure that all 16 pin sockets are in place before starting this group. This will prevent you from inadvertently inserting a 14 pin socket into a location that needs a 16 pin socket.

PART	LOCATION	DESCRIPTION	COMPLETE
14 pin socket	B-1	7400	
14 pin socket	B-2	7410	
14 pin socket	C-1	7404 (6800 only)	
14 pin socket	C-5	7427	
14 pin socket	C-6	7410	
14 pin socket	C-8	7450	
14 pin socket	C-9	7432	
14 pin socket	C-10	7402	
14 pin socket	C-12	7408	
14 pin socket	C-15	7400	
14 pin socket	D-10	7400	
14 pin socket	D-12	7404	

8. Solder In the 8 Pin Socket

Make sure that all 16 and 14 pin sockets are in place before starting this group. This will prevent you from inadvertently inserting an 8 pin socket in a location that needs a larger socket.

PART	LOCATION	DESCRIPTION	COMPLETE
8 pin socket	D-13	555 timer	

9. Repeat Check for Power and Ground Shorts

10. Solder In the 17 Decoupling Capacitors

These capacitors are labeled at 1.0 on the silk screen, but actual Apple 1 computers used .1 uF capacitors in these locations, and the kit supplies the .1 uF capacitors for this application. I found the easiest way to solder discrete components is to find a way hold the board vertically in a fixture. Place the component in the hole, and bend out the leads slightly, which will hold the component in place. Then solder on one leg and check to make sure that the component is fully seated before soldering on the other leg. Once soldered in, check your work, and then trim the leads using a small wire cutter. Locations for the decoupling capacitors have a capacitor symbol printed on the circuit board between the two holes. Don't mistake vias for component mounting holes. Vias have smaller diameter holes and are not connected to a mate with a capacitor symbol on the silk screen. Locations are approximate.

PART	LOCATION	DESCRIPTION	COMPLETE
.1 uF Capacitor	A-8	right of processor (+5V)	
.1 uF Capacitor	A-12, A-14, A-16, A-18	between ram sockets (+12V)	
.1 uF Capacitor	B-8	left of 74154 (+5V)	
.1 uF Capacitor	B-12, B-14, B-16, B18	between ram sockets (+12V)	
.1 uF Capacitor	B-13	above and to the right of this location (-5V)	
.1 uF Capacitor	C-8	between chips (+5V)	
.1 uF Capacitor	C-11, C-11	don't confuse location with .001 UF capacitors - slightly above and on each side of DS0025 (+5V, -12V)	
.1 uF Capacitor	C-15	right of 7400 (+5V)	
.1 uF Capacitor	D-8	between chips (+5V)	
.1 uF Capacitor	D-15	right of 74161 (+5V)	

11. Solder In the Remaining 6 Small Capacitors

These capacitors are labeled correctly on the silk screen. Use same technique as with decoupling capacitors. Locations are approximate.

PART	LOCATION	DESCRIPTION	COMPLETE
47 pF Capacitor	B-3	mica - left of 74123	
.001 uF Capacitor	B-3	right of 74123	
.01 uF Capacitor	C-11, C-11	left and right of DS0025 - don't confuse with decoupling capacitors (previous step)	
.01 uF Capacitor	D-12, D-12	one well above (don't put in resistor location), one to right of 7404	

12. Repeat Check for Power and Ground Shorts

13. Solder In Resistors

Use same process as used for capacitors when soldering. For extra good looks, align all the horizontally oriented resistors the same way (with the gold tolerance bar on the same end). Same thing with vertically oriented resistors.

PART	LOCATION	DESCRIPTION	COMPLETE
3000 ohm	A-5	orange-black-red	
3000 ohm (3)	A-8 (all three)	orange-black-red	
27K ohm	B-3	red-violet-orange	
10K ohm	B-3	brown-black-orange	
7.5K ohm (6)	C-2 (all six)	violet-green-red	
330 ohm	C-9	orange-orange-brown	
3000 ohm	C-11	orange-black-red	
1500 ohm	D-1	brown-green-red	
100 ohm pot	D-1	video adjust, orient so that center tap is towards top of board (connected to video out header)	
3000 ohm	D-2	orange-black-red	
3000 ohm (2)	D-4 (both)	orange-black-red	
3000 ohm (2)	D-5 (both)	orange-black-red	
390 ohm (2)	D-12 (both)	orange-white-brown	
10K ohm (2)	D-13 (both)	brown-black-orange	
3000 ohm (2)	inbetween D-14/15 (both)	orange-black-red	

14. Solder In Diodes



silk
screen
orientation



Diodes must be oriented correctly. There are two ends, anode and cathode. Be sure that orientation matches silks screen. Once oriented correctly, use same soldering process as used for resistors and capacitors when soldering.

PART	LOCATION	DESCRIPTION	COMPLETE
1n914	C-9	Orient correctly (pseudo or gate)	
1n914 (3)	D-15 (all three)	Orient correctly (pseudo or gate)	
1N4001 (4)	D-16	power rectifiers (+12V, -12V, -5V), take careful note of orientation, 2 are reversed, compared to the other 2	
MR500/A14F (4)	D-18	power rectifiers (+5V), take careful note of orientation, 2 are reversed, compared to the other 2. The unit pictured on the cover is MR500 type. If you have MR500 type, these diodes are too long to fit nicely between the holes. You will have to bend the leads under a bit and the diodes will be raised above the surface of the board. The A14F type are small round beads, but also have a line on the cathode end that should be used for orientation.	

15. Solder In Medium Electrolytic Caps and Transistor

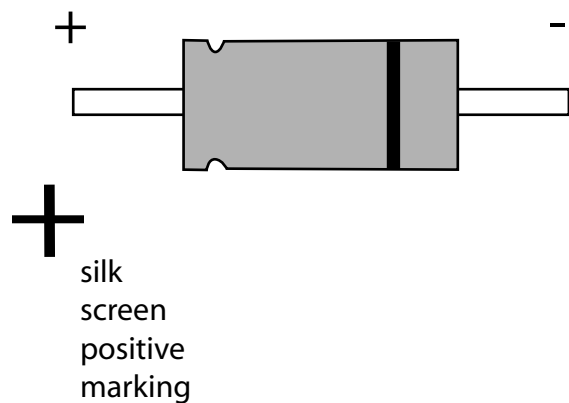

The electrolytic caps must be oriented correctly. There are two ends, positive and negative. Make sure that orientation is such that the positive end is at the small plus sign printed on the silk screen. Don't be confused, two of these caps are connected to a negative voltage rail. The plus side of these caps are actually connected to ground, which is correct. Failure to connect properly will likely result in premature failure. Failure of these types of caps, often results in explosions and fires, which can cause serious injury.

PART	LOCATION	DESCRIPTION	COMPLETE
22UF capacitor (2)	C-15	orient correctly, (one in each direction). -12V & +12V	
22UF capacitor	D-13	orient correctly. Cursor timer	
22UF capacitor	D-15	orient correctly. -5V	
22UF capacitor	D-15	orient correctly. cursor flasher	
MPS3704 Transistor	D-1	orient correctly - base connects to the two resistors, just below it. See cover photograph.	
14MHZ crystal	D-13	orientation not important	

16. Repeat Check for Power and Ground Shorts

17. Solder In Power and Video Connectors

Be careful that the power and video connectors are oriented correctly or you will not be able to properly insert the power plug. Refer to the photo on the cover of the manual, for reference.

PART	LOCATION	DESCRIPTION	COMPLETE
Video	D-1	4 pin header - shroud toward edge of board (see cover photo)	
Power	C-18	6 pin header- shroud toward edge of board (see cover photo)	

18. Solder In Small Voltage Regulators

The voltage regulators must be oriented correctly. Two of the three are oriented in one direction and the other in the opposite. Pay attention to the photo on the front cover. Once regulators are installed you will no longer have a completely open connection between power and ground planes.

PART	LOCATION	DESCRIPTION	COMPLETE
LM340-12 (LM7812)	D-16	orient correctly with the heat sink towards the top of the board, +12V.	
LM320 MP-12 (LM7912)	D-16	orient correctly, with heat sink towards bottom of board (opposite of LM340-12). -12V	
LM320 MP-5 (LM7905)	D-16	orient correctly, with heat sink towards bottom of board (like LM320 MP12)	

19. Solder In Large Power Smoothing Capacitors

The electrolytic caps must be oriented correctly. There are two ends, positive and negative. The positive end is clearly marked with a plus sign. Make sure that orientation is such that the positive end is at the small plus sign printed on the silk screen. Failure to connect properly will likely result in premature failure, Failure of these types of caps, often results in an explosion and/or fire, which can cause serious injury.

PART	LOCATION	DESCRIPTION	COMPLETE
5300UF	D-1	orient correctly, unregulated +5v	
2400UF(2)	C-17 (both)	orient correctly, (one in each direction). Unregulated -12V & +12V	

20. Repeat Check for Power and Ground Shorts

21. Attach Large +5 Volt Regulator and Heat Sink

The +5 volt regulator sits in the large heat sink and is bolted to the heat sink and board. You can use some of the provided thermal grease to increase heat transfer between the heat sink and the regulator by smearing a small amount of grease on the joint between them. Carefully bolt the regulator and heatsink to the board. Do not overtighten, or you could crush the board. Before soldering the pins of the regulator to the board, make sure that there is no short between those two pins and the ground plane (which is connected to the heat sink). Once regulators are installed you will no longer have a completely open connection between power and ground planes.

PART	LOCATION	DESCRIPTION	COMPLETE
LM340-12 (LM7812)	D-16	orient correctly with the heat sink towards the top of the board, +12V.	
LM320 MP-12 (LM7912)	D-16	orient correctly, with heat sink towards bottom of board (opposite of LM340-12). -12V	
LM320 MP-5 (LM7905)	D-16	orient correctly, with heat sink towards bottom of board (like LM320 MP12)	

PART	LOCATION	DESCRIPTION	COMPLETE
heatsink, bolts, nuts, +5 volt regulator	D-18	make sure unregulated and regulated +5 are not shorted to ground or each other.	

22. Repeat Check for Power and Ground Shorts

Congratulations, except for the expansion connector, you have finished soldering. You will no longer have completely open circuits between power and ground planes, but make sure that there are no “dead” shorts with little to no resistance.

23. Clean PCB of Rosin and By-products of Soldering

Clean the back of PCB of excess flux and rosin. 90% or higher isopropyl alcohol. IPA will dissolve soldering resin. Spray it on the back of the board and lightly scrub with a very soft brush that will not scratch the surface of the PCB. Soak up the IPA and contaminants with a clean soft cloth before it evaporates in order to remove the by products of soldering. Let dry overnight. Position a fan to blow over the board to make sure that all remaining moisture evaporates.

I have also discovered that “Windex” window cleaner can help remove the by-products from the soldering job. Removing contaminants is important as many kinds of rosins are corrosive.

24. Check Board for Solder Bridges and Cold Solder Joints

While the board is drying, you should carefully check your work for bad solder joints and solder bridges.

Chapter 3 – Initial Power Up

1. Build the Power Entry Module (PEM)

Instructions can be found in the Apple 1 Operations Manual that can be downloaded from many websites, such as <http://www.applefritter.com>. The only recommendation beyond what is in the manual, is that both fuse and switch should go on the “hot” side of the 110V AC input. I strongly recommend that the transformer and 110V AC wiring be placed in some kind of well ventilated enclosure. This is to make sure that no stray body parts touches any part of the 110V AC wiring. It must be well ventilated or fire could result from excessive heat build up.

2. Connect Power Supply and Power Up

Because this is a linear power supply, you can power up without populating the board with chips. Connect the power supply and power up. Check for any excessively hot components, especially in the power supply area. If any component is so hot, that touching it results in mediate pain, power down and check for shorts

3. Check Voltages

Check voltages on the board. The easiest places would be on the various power smoothing capacitors.

Voltage	LOCATION	ACTUAL VALUE	COMPLETE
+5 volt unregulated	5300UF capacitor at D-15	Roughly +10 Volts	
+12 volts unregulated	lower 2400UF capacitor at C-17	Roughly +20 Volts	
+12 volts unregulated-	Upper 2400UF capacitor at C-17	Roughly +20 Volts	
+5 Volts	horizontal 22UF capacitor at D-15	+5 Volts	
-5 Volts	vertical 22UF capacitor at D-16	-5 Volts	
+12 Volts	lower 22UF capacitor at C-15	+12 volts	
-12 Volts	upper 22UF capacitor at C-15	-12 Volts	

After checking out voltages, power off the Mimeo 1.

Chapter 4 – Bring Up The Video Section

Power off the computer before proceeding

1. Populate the Video Section

The Apple 1 computer is essentially two complete systems, a microcomputer and a video display system. Because they are largely independent, a large part of the video system can be brought up, prior to bringing up the microcomputer. Populate the ICs needed for the video section (all the ICs in rows C and D, plus the chip in location B-2).

A few IC's may be replacement parts, with different ID's than the original. All 8, 14 and 16 pin IC's are placed with pin one toward the bottom right of the board. The 24 and 40 pin ICs have pin one to the right. When reading the labeling on a chip, pin one is almost always on the bottom left corner. Refer to parts list, list of socket locations, and scan of my first prototype included on the cover this guide, if you are unsure about placement and orientation of components.

Some manufacturers don't make parts with legs spaced correctly. These ICs will be easier to insert, if the legs are bent to a angle that precisely aligns with the sockets. To do this, place the IC on it's side on a hard flat surface. One set of pins will be on the surface and pointed towards you. Keeping the IC's legs held firmly down, carefully roll the chip toward you to slightly bend the chip leads just a bit and then repeat with the process with the chip flipped to it's other side. Check for fit against socket and repeat accordingly.

When stuffing chips into sockets, be careful that pins are not inadvertently bent underneath the chip, instead of going into the socket. If you do bend a pin, they can be usually be straightened with a small pliers, if you do it carefully. Pins will usually break, right where they connect with the chip case, so do not bend the pin any more than necessary, especially at the joint, where it mates with the case.

PART	DESCRIPTION	LOCATION	QUANTITY	COMPLETE
2513	char ROM	D-2	1	
2504v	shift register	D-4a, D-4b, D-5a, D-5b, D-14a, D-14b, C-11b	7	
2519b	shift register	C-3	1	
DS0025C	clock driver	C-11a	1	
7400	quad NAND gate	C-15, D-10	2	
7402	quad NOR gate	C-10	1	
7404	hex inverter	D-12	1	
7408	quad and gate	C-12	1	
7410	three input nand	B-2, C-6	2	
74157	2:1 selector	C-4, C-14	2	
74160	4 bit counter	D-6	1	
74161 (74161A)	4 bit counter	D-7, D-9, D-11, D-15	4	
74161*	4 bit counter	D-8	1	
74166	shift register	D-1	1	
74174	hex flip flop	C-7	1	
74175	quad flip flop	C-13	1	
7427	triple 3 input nor gates	C-5	1	
7432	quad or gate	C-9	1	
7450	2 input and gate	C-8	1	
NE555	curser timer	D-13	1	
ICs (video section)			32	

* your kit may contain a mix of 74161 and 74161A parts. Using a 74161A part in location D-8 may result in intermittent operation

2. Connect a Video Display

The Apple 1 outputs a monochrome composite video signal. Any TV or receiver that has composite video input should work as a display device. However note that the composite video signal is digitally generated and some modern displays that digitally process the incoming video signal may have trouble locking into the Apple 1 video signal. Usually an older display without digital processing will perform well. Connect the video display device to the video header. You only need to connect pin 2 to the center conductor of a cable with a RCA jack on one end and pin 3 (ground) to the cable shield.

3. Checkout Video Section

Power on the computer. Check for any excessively hot components. If any component is so hot, that touching it results in pain, power down and check for shorts or other problems.

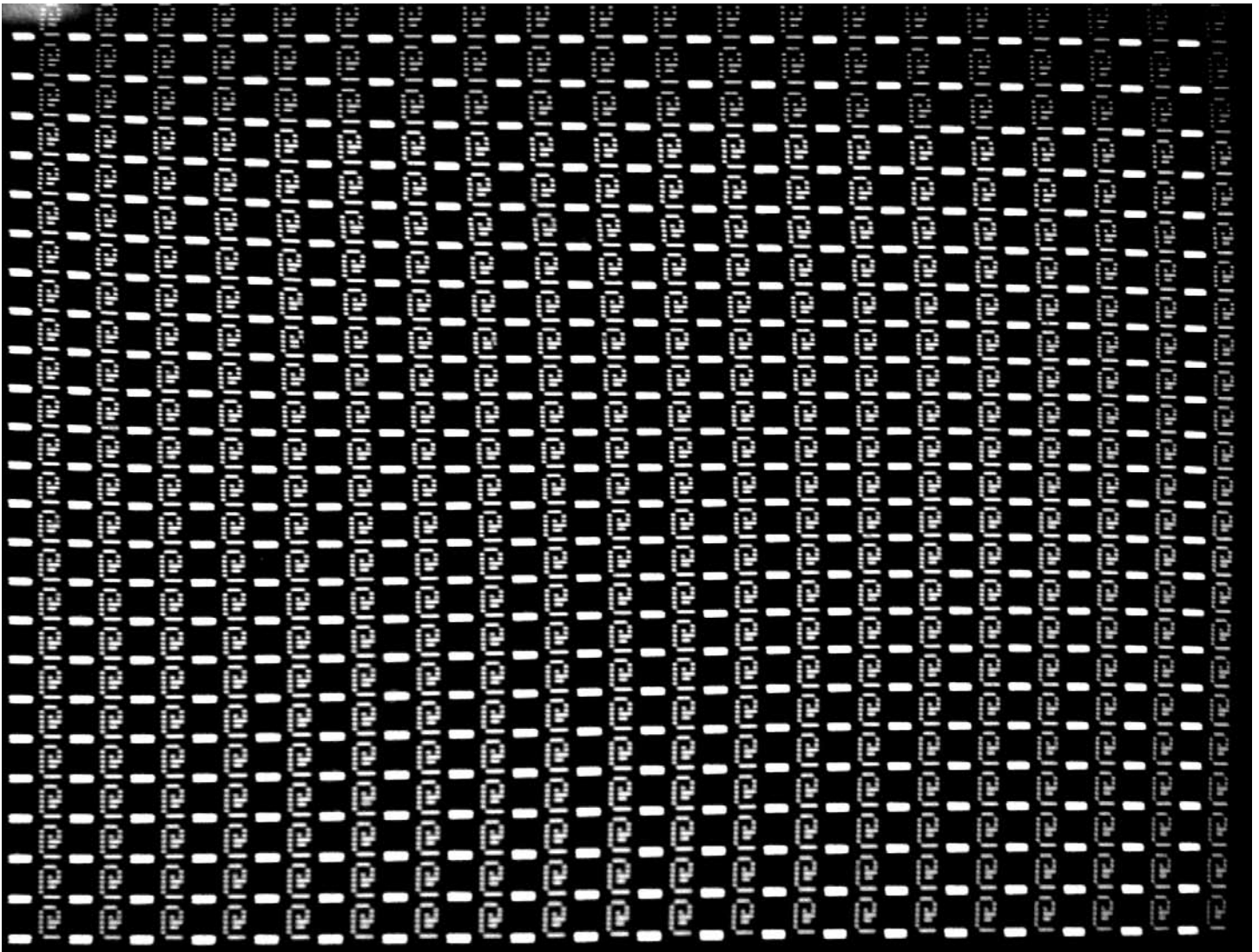

power up display (@ signs will be flashing)

If all is well, at this point, you should see a stable display with characters displayed on the screen as shown in this image. Briefly short pin 12 (clear screen) of the keyboard socket to +5v and the screen should become clear. If the display is not working, then you must determine the fault through debugging techniques. See the chapter on debugging for some hints.

Chapter 5 – Populate and Check out the Computer Section

Power off the computer before proceeding

1. Populate the Computer Section

Once the video section is basically working, you can bring up the computer section. To start with you only need to populate one bank of DRAM. Populate the processor section ICs using the same method as used for bringing up the video section.

PART	DESCRIPTION	LOCATION	QUANTITY	COMPLETE
8T97	bus driver	A-9, A-10	2	
MMI 3601 (LSB)	256x4 PROM, LSB (least significant nibble)	A-1	1	
MMI 3601 (MSB)	256x4 PROM MSB (most significant nibble)	A-2	1	
6820	parallel interface adapter	A-4	1	
6502	processor	A-7	1	
7400	quad NAND gate	B-1	1	
74123	dual one-shot	B-3	1	
74154	4:16 demux	B-9	1	
74S257	2:1 selector	B-5, B-6, B-7, B-8	4	
MK4096	4kx1 DRAM bank "X"	B-11 through B-18	8	
ICs (processor section)			21	

At this point, all IC locations should be populated, except DRAM row "W" and the 6800 only location at C1.

2. Solder Motherboard Jumpers

JUMPER	LOCATION	
6502	A-5	Use a blob of solder to connect the two traces
6502	A-8	Use a blob of solder to connect the two traces
NO DMA	A-10	Use a blob of solder to connect the two traces. If you add an expansion card that controls the DMA line, then you should remove this solder jumper
DRAM	B-9	For initial bring up, DRAM bank X is jumpered by adding a blob of solder to connect address select "0" to bank "X". Later on when bank "W" is added, it will normally be jumpered to bank "E" to enable running BASIC
PROM	B-9	Use a blob of solder to short address "F" to "Y"
PIA	B-9	Use a short jumper wire to short address "D" to "Z"

3. Power Up

Power up and you should see the same display as when you brought up the video section. Check for any excessively hot components. If any component is so hot, that touching it results in pain, power down and check for shorts or other problems.

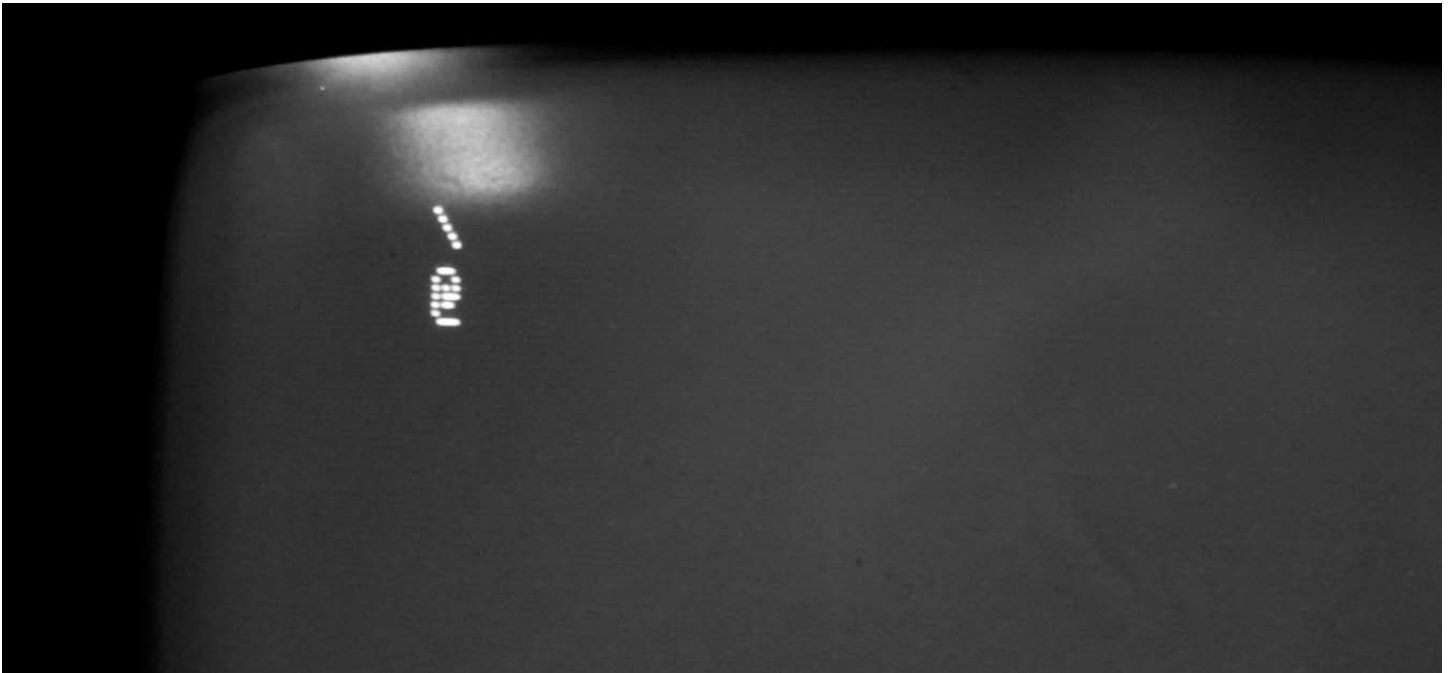

After both clear and reset, you have a backslash and prompt at the top left corner of the screen

Briefly short pin 12 (clear screen) of the keyboard socket to +5v and the screen should become clear. At this point you should be able to reset the processor section and see a prompt be displayed. To reset the system and get a prompt, use a temporary jumper to short pin 1 of the keyboard connector to a nearby ground pin (pin 9 of keyboard connector).

Note that without a keyboard attached, random characters may be input. This is because the keyboard strobe input to the PIA is floating. To stop this you can use a temporarily jumper to short pin 40 of the 6840 to pin 1 of the 6502.

4. Connect a Keyboard and You Should be Operational

Refer to the Apple 1 Operations Manual for keyboard interface specification. Apple II and II plus keyboards have different pinouts, but may be adapted to the Apple 1 keyboard interface through simple rewiring. Miswiring has a good possibility of damaging components on both the Apple 1 and the keyboard, so go slow and double or triple check your work before powering up. There is a good description of an Apple II keyboard adaptor at John Calende's blog <http://apple1computer.blogspot.com/>.

Chapter 6 - Mount Card Edge Connector

1. Cut Off Mounting Ears (optional)

You may have received with your kit, an edge connector with mounting ears. Original Apple 1s had edge connectors without ears. Using a razor saw (available at any hobby store), you can carefully cut off the ears to more closely mimic the look of the edge connector of an original Apple 1. Polishing the cut surface will remove any rough surfaces. A polishing bit in a rotary tool can be used for this purpose.

2. Test Fit

This connector may fit somewhat tightly into the holes on the PCB. If it doesn't seat correctly, check for bent pins on the connectors. Straighten any bent pins and carefully insert the connector into the PCB.

3. Solder Card Edge Connector

Tack down a couple of pins on each end of the connector and check for good seating of the connector in the PCB. Then proceed to solder the remaining pins.

PART	LOCATION	DESCRIPTION	COMPLETE
Card edge connector	J-3	expansion slot	

4. Clean PCB

5. Powerup and Retest the Computer

Chapter 7 – Troubleshooting and Help

The complexity of the processor and video systems can make troubleshooting an Apple I a bit involved. A good job of soldering the components into place should eliminate most if not all trouble. First step, in case of trouble, should be to check for bad solder joints or bridges. In fact, except for some initial issues with bad or incorrect components, which I have corrected in the kits I am providing to you, I have had no trouble bringing up my initial prototype.

Refer to my Apple II repair page at www.willegal.net for some general troubleshooting hints. Note, that with a properly constructed replica, you should have no trouble with intermittent sockets that are constant issues with vintage Apple computers.

Feel free to send email to: mike@willegal.net if you run into difficulties.